

Installation and Assembly - Solid•Point™ Universal Adapter bracket for Large Flat Panel Screens

Model:
PLP UN-1

Parts List

PART #	QTY.	DESCRIPTION
AA	200-0333	1 adapter bracket
BB	200-1302	2 vertical bracket
CC	520-1151	4 10-32 x 3/8" serrated head socket pin screw
DD	540-9440	6 1/4" washer
EE	520-1050	6 M6 x 1 x 12 mm socket pin screw
FF	520-1064	8 M5 x .8 x 12 mm socket pin screw
GG	520-1156	8 M4 x .7 x 10 mm serrated socket pin screw
HH	520-1068	6 M8 x 1.25 x 15mm socket pin screw
II	520-1101	4 M8 x 25 mm socket pin screw
JJ	540-9400	8 #10 washer
KK	540-1015	4 1/2" spacer
LL	560-9646	1 security allen wrench
MM	520-1152	4 M8 x 40 mm socket pin screw

Some parts may appear slightly different than illustrated.

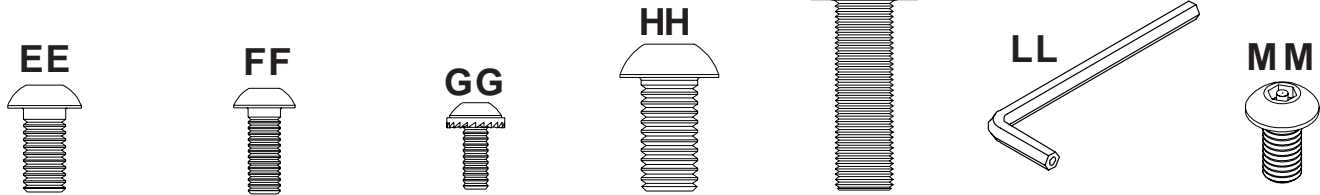

For easier reference during assembly all fasteners on this page are scaled 1:1

To assemble the adapter bracket (AA) to your flat screen product, please refer to the compatibility chart and configurations table on accompanying screen compatibility chart. First, locate your flat screen product in the compatibility chart using the manufacturers name and model number. Next, note the configuration letter shown in the far right hand column. Finally, use the configurations table, which appears after the compatibility chart, to determine the correct mounting hardware for your flat screen product.

1 Slide vertical brackets (**BB**) onto c-channels as shown below. Refer to the table on the last page of the screen compatibility chart to determine the proper assembly of the vertical bracket (**BB**). For standard bracket mounting, see figure 3. For reverse bracket mounting, see figure 4.

Example: For a Toshiba model 50 HP82 50" screen, assemble the vertical bracket (**BB**) as shown in figure 4 below (reverse bracket mounting).

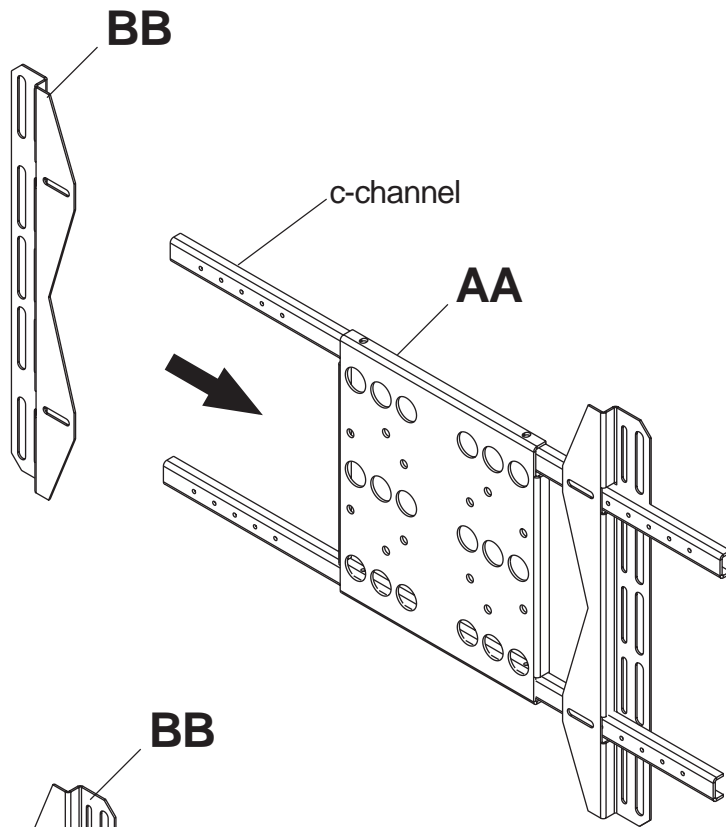

fig. 3
Bracket Mounting: Standard

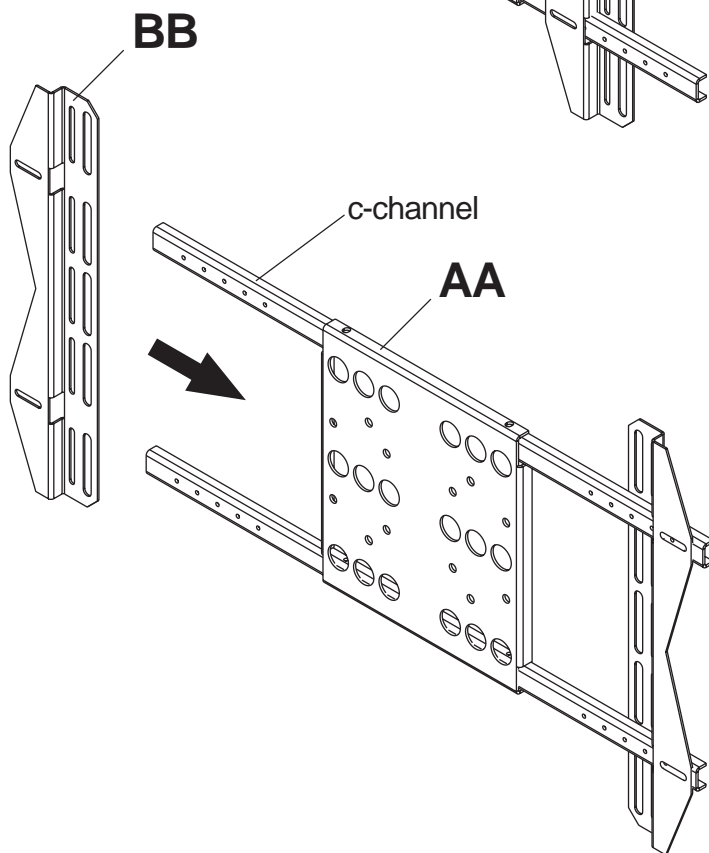
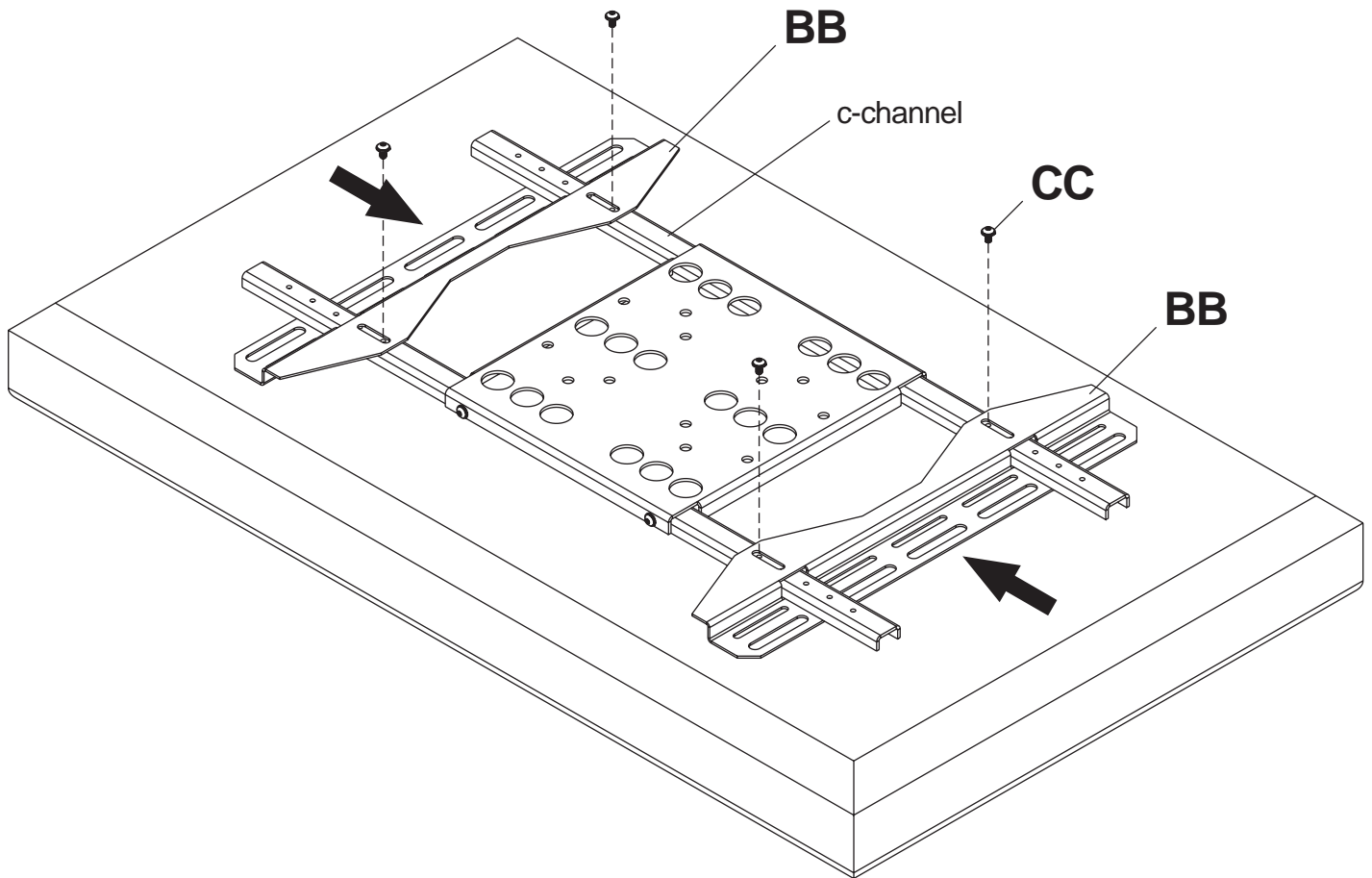

fig. 4
Bracket Mounting: Reverse

- 2 Set a cloth on the floor to prevent scratching the screen. Place the screen on the floor face down. If the screen has knobs on the back, remove them. Place adapter bracket (**AA**) on the center of the screen. Slide the vertical brackets (**BB**) along the c-channels of the adapter bracket (**AA**) until the slots on the back of the vertical brackets (**BB**) are aligned to the holes on the back of the screen. Fasten vertical brackets (**BB**) to c-channels using four 10-32 x 3/8" serrated head socket pin screws (**CC**).

Note: Do not fully tighten the screws (**CC**) to allow the adapter bracket to slide along the vertical brackets (**BB**) freely.



3 Slide the vertical brackets (**BB**) along the c-channels of the adapter bracket (**AA**) until the slots on the back of the vertical brackets (**BB**) are aligned to the holes on the back of screen. Fully tighten the four 10-32 x 3/8" serrated head socket pin screws (**CC**) which hold the vertical brackets (**BB**) to the c-channels. Refer to the accompanying screen compatibility chart to determine the proper fasteners to use. Attach the assembled adapter bracket to the back of the screen using screws, upper and lower spacers as pictured. Verify that all holes are properly aligned, then use the security allen wrench (**LL**) to tighten the screws.

Note: See figure 5 below for slot sizes.

Example: For a Toshiba model 50 HP82 50" screen, attach the vertical brackets (**BB**) to the screen using eight M4 x 10 mm serrated socket pin screws (**GG**) or M5 x 12 mm socket pin screws (**FF**) through the small slots on the vertical brackets (**BB**). Please refer to the corresponding configuration note for more details. Upper spacers (**JJ**) are required for this configuration.

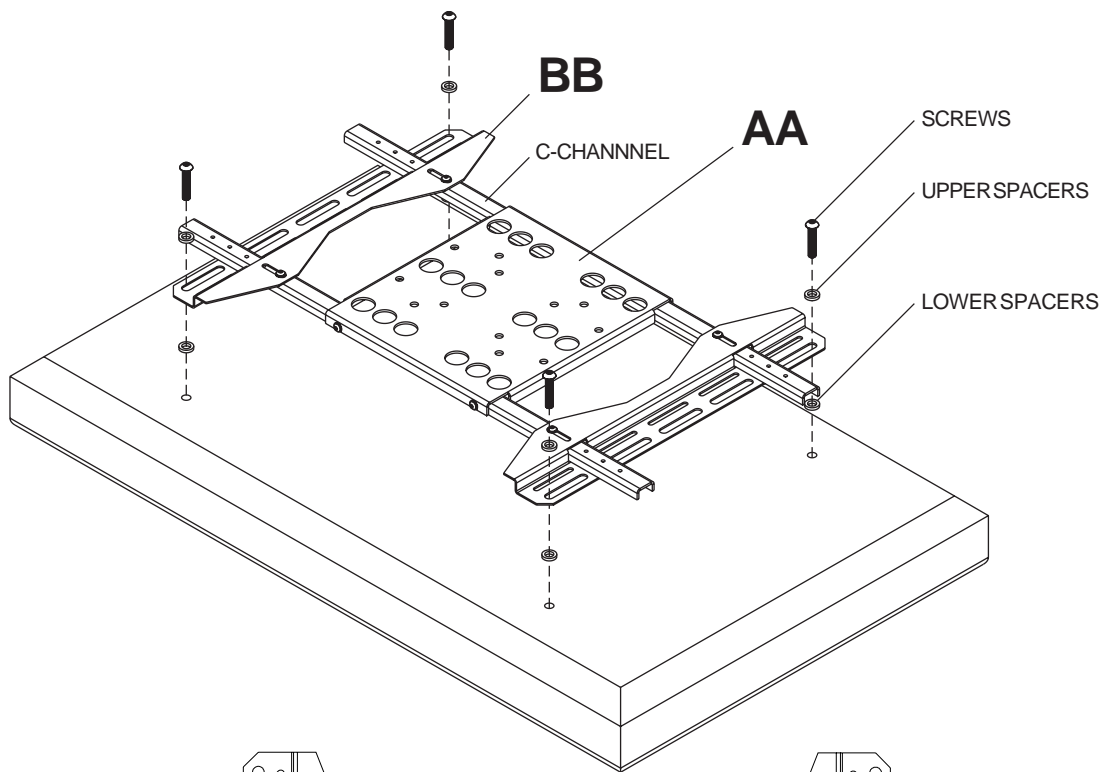
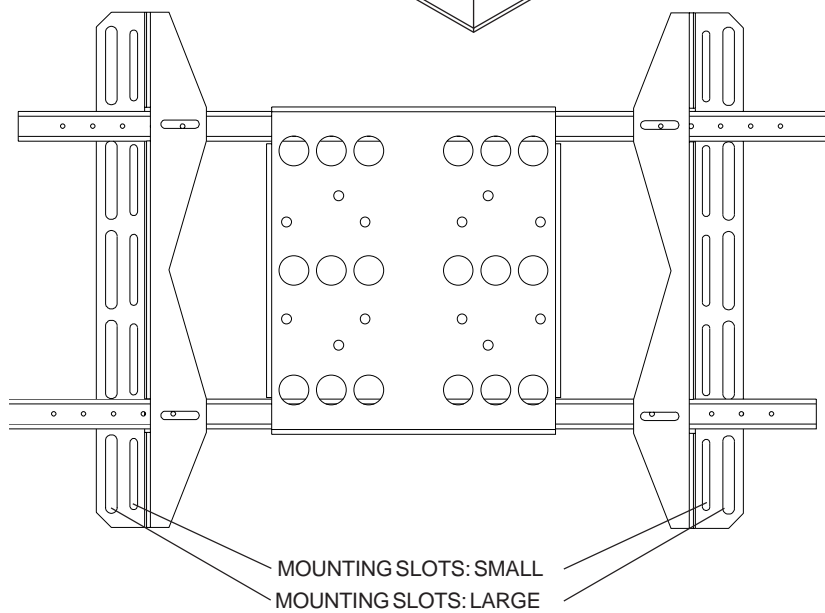

fig. 5
Mounting Slots

SMALL SLOTS ARE USED FOR M4 AND M5 SCREWS.

LARGE SLOTS ARE USED FOR M6 AND M8 SCREWS.



MOUNTING SLOTS: SMALL
MOUNTING SLOTS: LARGE